

XTR™ 5 and XTR™ 7 Airless Spray Gun

312145K

EN

For use with protective coating materials.

XTR 5

5000 psi (35 MPa, 345 bar) Maximum Working Pressure

XTR 7

7250 psi (50 MPa, 500 bar) Maximum Working Pressure

See page **Parts**, page 14, for model information.



Important Safety Instructions

Read all warnings and instructions in this manual and in your sprayer instruction manual before using the equipment. Save all instructions.



Important Medical Information

Read the medical alert card provided with the gun. It contains injection injury treatment information for a doctor. Keep it with you when operating the equipment.

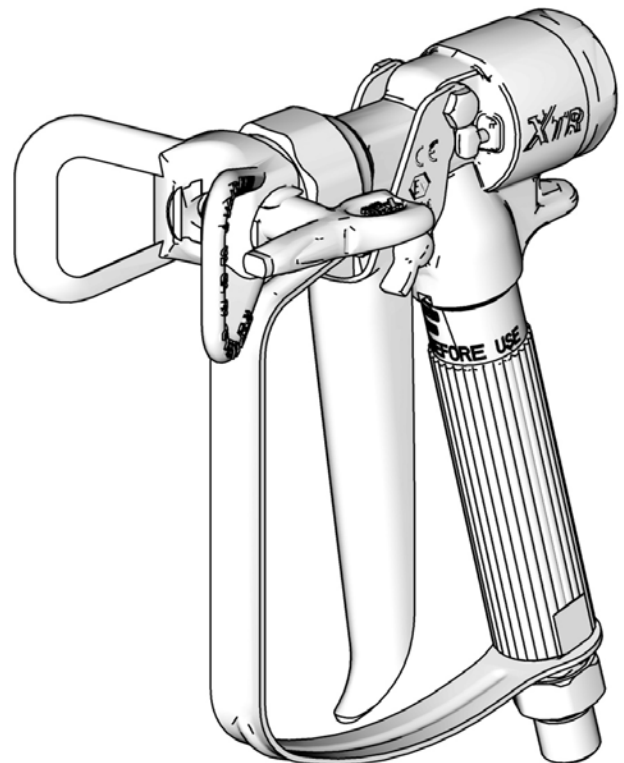

ti5045b

Contents

Warnings	3	Repair	11
Pressure Relief Procedure	6	Disassembly	11
Grounding	6	Trigger Removal	11
System Requirements	7	Assembly	12
Gun Trigger Lock	7	Test Gun Before Using	12
Spray Tip Installation	8	Parts	14
RAC Tip	8	XTR5	14
Flat Tip	8	XTR7	16
Operation	9	Technical Specifications	19
Adjusting Spray Pattern	9	Graco Standard Warranty	20
Cleaning Tips/Clearing Clogs	9	Graco Information	20
Maintenance	10		
Flushing	10		
Cleaning and Replacing Filter	10		
Cleanup	10		

Warnings

The following warnings are for the setup, use, grounding, maintenance, and repair of this equipment. The exclamation point symbol alerts you to a general warning and the hazard symbols refer to procedure-specific risks. When these symbols appear in the body of this manual or on warning labels, refer back to these Warnings. Product-specific hazard symbols and warnings not covered in this section may appear throughout the body of this manual where applicable.

 <h1 style="margin: 0;">WARNING</h1>	
	<p>SKIN INJECTION HAZARD</p> <p>High-pressure fluid from gun, hose leaks, or ruptured components will pierce skin. This may look like just a cut, but it is a serious injury that can result in amputation. Get immediate surgical treatment.</p> <ul style="list-style-type: none"> • Do not spray without tip guard and trigger guard installed. • Engage trigger lock when not spraying. • Do not point gun at anyone or at any part of the body. • Do not put your hand over the spray tip. • Do not stop or deflect leaks with your hand, body, glove, or rag. • Follow the Pressure Relief Procedure when you stop spraying and before cleaning, checking, or servicing equipment. • Tighten all fluid connections before operating the equipment. • Check hoses and couplings daily. Replace worn or damaged parts immediately.
	<p>FIRE AND EXPLOSION HAZARD</p> <p>Flammable fumes, such as solvent and paint fumes, in work area can ignite or explode. Paint or solvent flowing through the equipment can cause static sparking. To help prevent fire and explosion:</p> <ul style="list-style-type: none"> • Use equipment only in well-ventilated area. • Eliminate all ignition sources; such as pilot lights, cigarettes, portable electric lamps, and plastic drop cloths (potential static sparking). • Ground all equipment in the work area. See Grounding instructions. • Never spray or flush solvent at high pressure. • Keep work area free of debris, including solvent, rags and gasoline. • Do not plug or unplug power cords, or turn power or light switches on or off when flammable fumes are present. • Use only grounded hoses. • Hold gun firmly to side of grounded pail when triggering into pail. Do not use pail liners unless they are anti-static or conductive. • Stop operation immediately if static sparking occurs or you feel a shock. Do not use equipment until you identify and correct the problem. • Keep a working fire extinguisher in the work area.



WARNING



EQUIPMENT MISUSE HAZARD

Misuse can cause death or serious injury.

- Do not operate the unit when fatigued or under the influence of drugs or alcohol.
- Do not exceed the maximum working pressure or temperature rating of the lowest rated system component. See **Technical Specifications** in all equipment manuals.
- Use fluids and solvents that are compatible with equipment wetted parts. See **Technical Specifications** in all equipment manuals. Read fluid and solvent manufacturer's warnings. For complete information about your material, request Safety Data Sheets (SDSs) from distributor or retailer.
- Do not leave the work area while equipment is energized or under pressure.
- Turn off all equipment and follow the **Pressure Relief Procedure** when equipment is not in use.
- Check equipment daily. Repair or replace worn or damaged parts immediately with genuine manufacturer's replacement parts only.
- Do not alter or modify equipment. Alterations or modifications may void agency approvals and create safety hazards.
- Make sure all equipment is rated and approved for the environment in which you are using it.
- Use equipment only for its intended purpose. Call your distributor for information.
- Route hoses and cables away from traffic areas, sharp edges, moving parts, and hot surfaces.
- Do not kink or over bend hoses or use hoses to pull equipment.
- Keep children and animals away from work area.
- Comply with all applicable safety regulations.



PRESSURIZED ALUMINUM PARTS HAZARD

Use of fluids that are incompatible with aluminum in pressurized equipment can cause serious chemical reaction and equipment rupture. Failure to follow this warning can result in death, serious injury, or property damage.

- Do not use 1,1,1-trichloroethane, methylene chloride, other halogenated hydrocarbon solvents or fluids containing such solvents.
- Do not use chlorine bleach.
- Many other fluids may contain chemicals that can react with aluminum. Contact your material supplier for compatibility.



TOXIC FLUID OR FUMES HAZARD

Toxic fluids or fumes can cause serious injury or death if splashed in the eyes or on skin, inhaled or swallowed.

- Read Safety Data Sheets (SDSs) for handling instructions and to know the specific hazards of the fluids you are using, including the effects of long-term exposure.
- When spraying, servicing equipment, or when in the work area, always keep work area well-ventilated and always wear appropriate personal protective equipment. See **PERSONAL PROTECTIVE EQUIPMENT** warnings in this manual.
- Store hazardous fluid in approved containers, and dispose of it according to applicable guidelines.



BURN HAZARD

Equipment surfaces and fluid that is heated can become very hot during operation. To avoid severe burns:

- Do not touch hot fluid or equipment.

**WARNING****RECOIL HAZARD**

Gun may recoil when triggered. If you are not standing securely, you could fall and be seriously injured.

**PERSONAL PROTECTIVE EQUIPMENT**

Always wear appropriate personal protective equipment and cover all skin when spraying, servicing equipment, or when in the work area. Protective equipment helps prevent serious injury, including long-term exposure; inhalation of toxic fumes, mists or vapors; allergic reaction; burns; eye injury and hearing loss. This protective equipment includes but is not limited to:

- A properly fitting respirator, which may include a supplied-air respirator, chemically impermeable gloves, protective clothing and foot coverings as recommended by the fluid manufacturer and local regulatory authority.
- Protective eyewear and hearing protection.

Pressure Relief Procedure



Follow the Pressure Relief Procedure whenever you see this symbol.

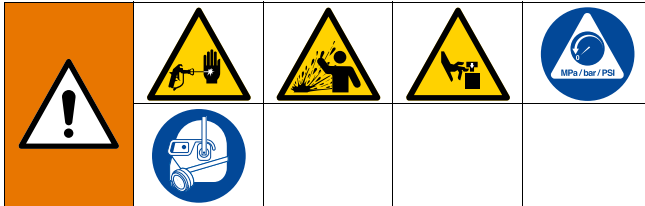

This equipment stays pressurized until pressure is manually relieved. To help prevent serious injury from pressurized fluid, such as skin injection, splashing fluid and moving parts, follow the Pressure Relief Procedure when you stop spraying and before cleaning, checking, or servicing the equipment.

1. Engage the trigger lock.
2. Shut off the pump.
3. Disengage the trigger lock.
4. Hold a metal part of the gun firmly to a grounded metal pail. Trigger the gun to relieve pressure.
5. Engage the trigger lock.
6. Open the fluid drain valve over a waste container (see **System Requirements**, page 7). Leave drain valve open.

If pressure is not fully relieved:

- Spray tip is clogged. For RAC tip, see **Cleaning Tips/Clearing Clogs**, page 9. For flat tip, slowly loosen tip guard retaining nut to relieve pressure. Remove and clean the tip.
- Hose is clogged. Slowly loosen hose end coupling to relieve pressure. Clean the hose obstruction.

Grounding

<p>The equipment must be grounded to reduce the risk of static sparking. Static sparking can cause fumes to ignite or explode. Grounding provides an escape wire for the electric current.</p>				

Check your local electrical code and pump or sprayer manual for detailed grounding instructions.

Spray gun: ground through connection to a properly grounded fluid hose and pump.

Fluid hose: use only electrically conductive hoses with a maximum of 500 ft. (150 m) combined hose length to ensure grounding continuity. Check electrical resistance of hoses. If total resistance to ground exceeds 29 megohms, replace hose immediately.

Fluid supply container: follow local code.

Object being sprayed: follow local code.



Solvent pails used when flushing: follow local code. Use only conductive metal pails, placed on a grounded surface. Do not place the pail on a nonconductive surface, such as paper or cardboard, which interrupts grounding continuity.

To maintain grounding continuity when flushing or relieving pressure: hold metal part of the spray gun/dispense valve firmly to the side of a grounded metal pail, then trigger the gun/valve.

System Requirements

- Install a bleed-type master air valve on a pneumatic pump air supply line to relieve air trapped between this valve and pump after air regulator is shut off. Trapped air can cause the pump to cycle unexpectedly.
- Install a fluid drain valve between the pump and gun to relieve pressure in displacement pump, hose, and gun. Triggering to relieve pressure may not be sufficient. See the **Pressure Relief Procedure**, page 6.

Gun Trigger Lock

				
<p>To prevent injury when the gun is not in use, always engage the gun's trigger lock if unit is being shut down or left unattended. A wallet-sized warning card with important injection treatment information is included with the gun. Additional cards are available at no charge. Provide a card to all operators.</p> <p>The trigger lock must move freely, and easily snap into the locked position. If the trigger lock is damaged or movement is restricted, replace with new trigger kit (16) immediately.</p>				

Trigger Locked
(no spray)

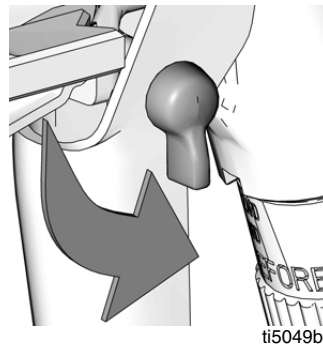

Trigger Unlocked
(spray)

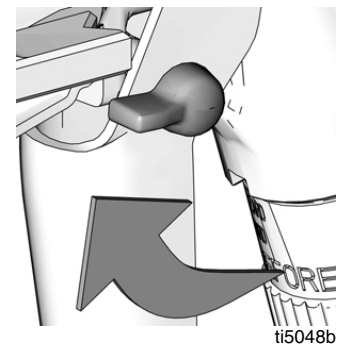

Spray Tip Installation

<p>To avoid serious injury from skin injection, do not put your hand in front of the spray tip when installing or removing the spray tip and tip guard.</p>				

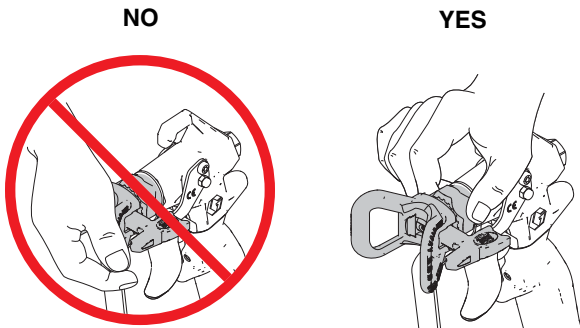

RAC Tip

1. Follow the **Pressure Relief Procedure**, page 6. Engage the trigger lock.
2. Snap gasket (20b) on fluid seal (20a). Use tool (A) to insert gasket and seal into housing, seal first. Tip the tool to remove it when seal is in place.

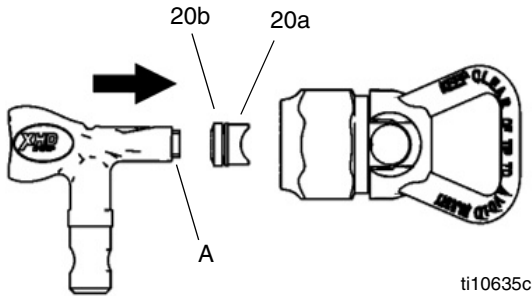

3. Install tip cylinder (20c) as shown. Turn 90° counterclockwise to spray position, so the arrow faces forward. Install assembled RAC onto spray gun.

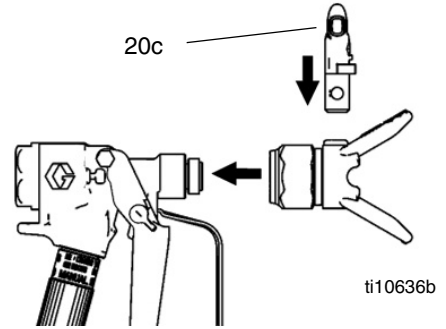

Flat Tip

1. Follow the **Pressure Relief Procedure**, page 6. Engage the trigger lock.
2. Insert tip (32) and gasket (30) into back of guard (31).
3. Install the guard over the end of the gun.

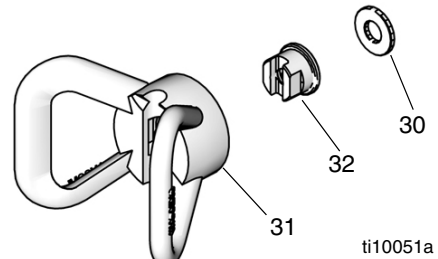

Operation

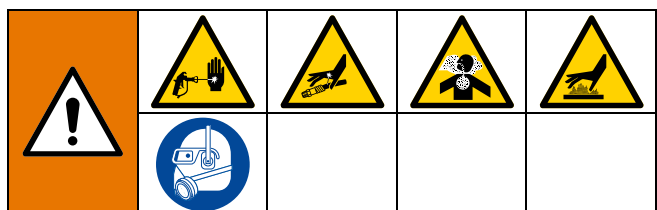

1. Connect a grounded fluid hose.
2. Without spray tip attached, flush the pump. Use the lowest pressure possible.
3. Prime. Refer to the sprayer manual.
4. Follow the **Pressure Relief Procedure**, page 6.
5. Install the spray tip and tip guard.
6. RAC tips only: In spray position, arrow on tip cylinder (20c) faces forward.

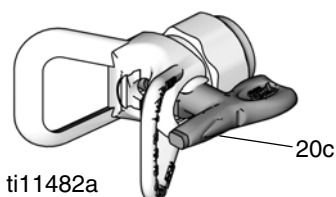

7. Hold the gun perpendicular and approximately 12 inches (304 mm) from the surface. Wear gloves if the fluid temperature exceeds 110°F (43°C).
8. Move the gun first, then pull the gun trigger to spray onto test paper.
 - a. Adjust the fluid pressure until spray is completely atomized.
 - b. If adjusting the pressure does not give a good spray pattern, follow **Pressure Relief Procedure**, page 6, then try another tip size.
9. Trigger the gun full-open or full-close.

Adjusting Spray Pattern

The spray tip orifice and spray angle determine pattern coverage and size. When you need more coverage, use a larger spray tip rather than increasing fluid pressure.

1. Follow the **Pressure Relief Procedure**, page 6. Engage the trigger lock.
2. Loosen tip guard retaining nut.
3. Align the guard horizontally to spray a horizontal pattern. Align guard vertically to spray a vertical pattern.
4. Tighten the nut.

Cleaning Tips/Clearing Clogs

NOTE: Clean the tip guard at the end of each workday.

1. Follow the **Pressure Relief Procedure**, page 6. Engage the trigger lock.
2. Clean the spray tip.
 - a. RAC tips: Rotate tip 180° so arrow on tip cylinder (20c) faces backward. Disengage the trigger lock. Trigger the gun into a pail or onto the ground to remove clog. Engage the trigger lock. Rotate tip 180° back to spray position.

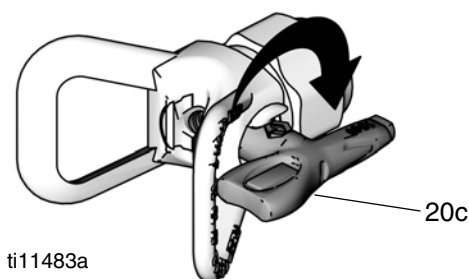

- b. Flat tips: Remove tip and clean with a solvent-soaked brush.
3. If the RAC tip is still clogged:
 - a. Shut off sprayer and disconnect power source.
 - b. Open the fluid drain valve (see **System Requirements**, page 7) to relieve pressure.
 - c. Remove and clean the spray tip.

Maintenance



Failure to clean or replace the filter or damaged handle bore can result in serious injury.

Before performing any maintenance on the gun, read all warnings in this manual and relieve pressure.

Flushing

Flush the pump and gun before fluid can dry in it. If available, use flushing procedure provided in your pump manual instead of this procedure.

1. Follow the **Pressure Relief Procedure**, page 6. Engage the trigger lock.
2. Remove the spray tip and guard from gun. Clean with solvent.
3. Put the pump intake in a grounded pail of compatible solvent.
4. Start the pump at its lowest pressure.
5. Disengage trigger lock, then trigger the gun into the paint pail. When solvent appears, release trigger.
6. Trigger the gun into solvent pail. Circulate fluid until the system is thoroughly flushed.
7. Follow the **Pressure Relief Procedure**, page 6. Engage the trigger lock.

Cleaning and Replacing Filter

(Not applicable for XTR510, XTR706, and 17V677)

1. Follow the **Pressure Relief Procedure**, page 6. Engage the trigger lock.

2. Disconnect the trigger guard from the gun body by pushing up on the guard hook and pulling it out of the notch.

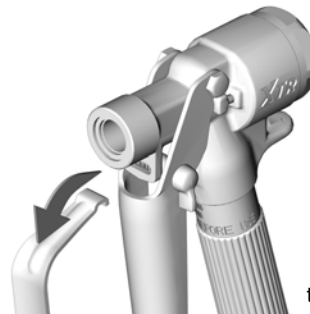

3. The trigger guard beneath the gun handle can then be used as a wrench to loosen the nut.

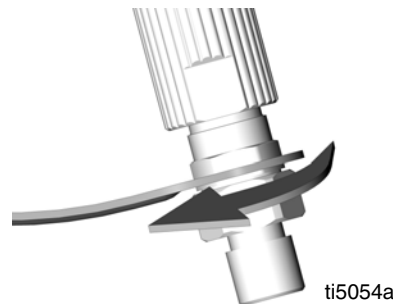

4. When the alignment notches are no longer engaged, use your hand to twist the handle and remove it from the gun head.
5. Remove the filter.
6. Clean the filter using a soft brush.
7. Replace the filter.
8. Apply a light coating of grease to the threads and then attach.
9. Use the trigger guard to tighten the nut.
10. Reattach the trigger guard to the gun.

Cleanup

Flush the gun after each work shift and store in a dry location. Do not leave the gun or any parts in water or cleaning solvents.

Repair



Disassembly

1. Follow the **Pressure Relief Procedure**, page 6. Engage the trigger lock.
2. Disconnect the fluid hose. Remove the RAC tip guard and tip (19 and 20a–20c) or flat tip guard and tip (30, 31, and 32).
3. RAC tip only: Use tool to push gasket and seal out the back of the housing.

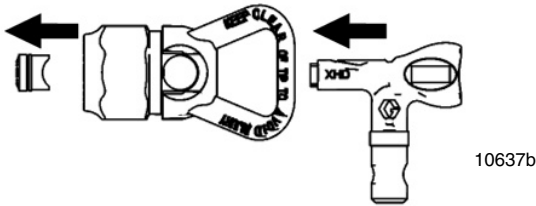

4. Using a wrench, remove the cap (4) with spring (5) (releases spring tension on needle).
5. Remove the valve seat (10) and gasket (9).
6. While holding the needle (36), use tool to remove the needle retainer (6).

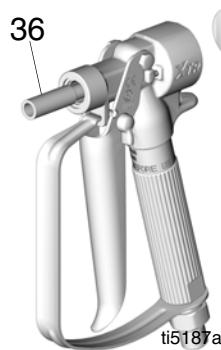

7. Pull the needle (8) out.
8. Using a socket wrench, remove the seal retainer (2) from the back of the gun. Use a pick to remove the gasket (3).
9. Clean and replace parts as needed.

Trigger Removal

NOTE: To avoid losing parts, be ready for two actuator pins (7) to fall out of the gun body when the trigger (16) is removed.

XTR 7 Guns

1. Using a wrench, remove screw (16b) from the pivot pin (16a).
2. Slide the pivot pin (16a) out of the gun body, and remove the trigger (16).
3. Before reinstalling the trigger, grease the actuator pins (7) and the pivot pin (16a).

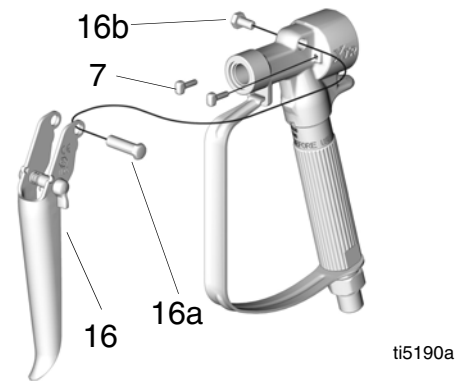

XTR 5 Guns

1. Using a socket wrench, remove screw (16c) from each side of the gun body and remove the trigger.
2. Before reinstalling the trigger, grease the actuator pins (7).

Assembly

1. Press a new gasket (3*) into the gun body. Lightly grease the seal retainer (2*) and install. Torque to 48–72 in-lb (5–8 N•m).
2. Lightly grease and replace the needle (8*). Press the needle through the seal retainer.

NOTICE

Use only tool (36) and fingers to tighten the needle. Do not overtighten or breakage may occur.

3. Apply light-strength Loctite™ to needle threads. Holding the needle with too (36*), install needle retainer (6). Tighten until it bottoms out. Do not overtighten.
4. Lightly grease valve seat (10*) threads. Squeeze the trigger to retract the needle and install gasket (9*) and valve seat (10*). Torque valve seat to 26–32 ft-lb (34–43 N•m).
5. Grease and install the spring (5) and cap (4). Tighten the cap to 10–13 ft-lb (8–10 N•m).

Test Gun Before Using

1. Engage the trigger lock. Connect the fluid hose to the gun.
2. Start and prime the pump.
3. Disengage the trigger lock and trigger the gun into a metal waste container.
4. Release the trigger. The gun should immediately stop spraying and there should be no leaks. If there is a problem, follow the **Pressure Relief Procedure**, page 6. Check through the **Assembly** procedure and correct any problem.
5. Install the tip and tip guard before regular use.

Parts

XTR5

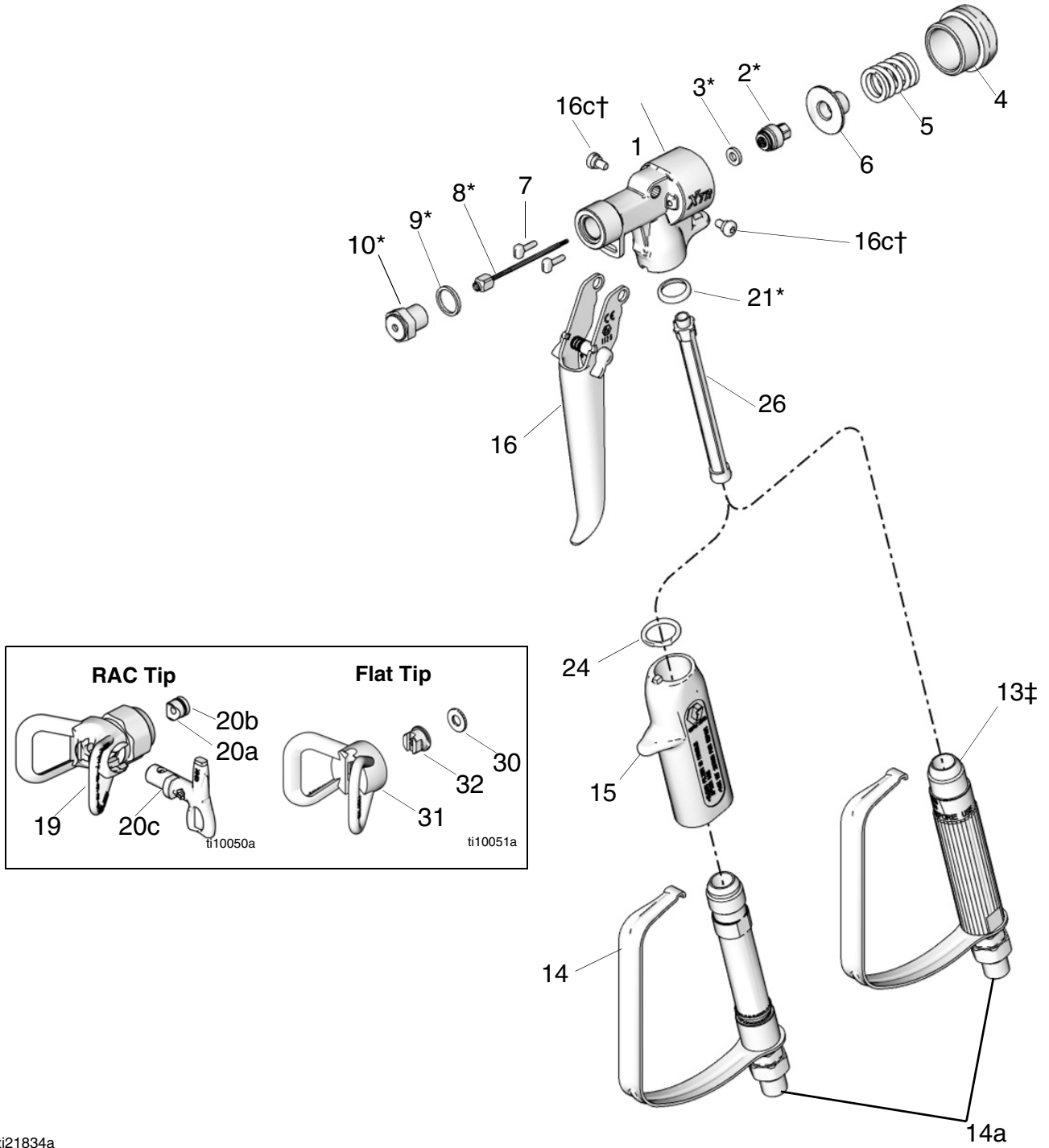

ti21834a

Ref.	Part	Description	Quantity						
			XTR500	XTR501	XTR502	XTR503	XTR504	XTR505	XTR510
1	15J771	BODY, gun	1	1	1	1	1	1	1
2*	245881	SEAL, retainer assembly	1	1	1	1	1	1	1
3*	---	GASKET	1	1	1	1	1	1	1
4	15K000	CAP, end	1	1	1	1	1	1	1
5	117350	SPRING	1	1	1	1	1	1	1
6	15E088	RETAINER, needle	1	1	1	1	1	1	1
7	15E085	PIN, actuator	2	2	2	2	2	2	2
8*	248591	NEEDLE	1	1	1	1	1	1	1
9*	156766	GASKET	1	1	1	1	1	1	1
10*	245858	SEAT, valve	1	1	1	1	1	1	1
13‡	255275	HANDLE; includes trigger guard and swivel	1	1			1	1	1
14	248952	HANDLE KIT			1	1			
14a★	---	SWIVEL							
15	276997	HANDLE SLEEVE, insulated			1	1			
16†	287449	TRIGGER KIT, 4-finger, straight; includes 16c	1	1			1		1
	287451	TRIGGER KIT, 4-finger, curved; includes 16c			1				
	287450	TRIGGER KIT, 2-finger; includes 16c				1		1	
16c†	117602	SCREW, shoulder, #8-32	2	2	2	2	2	2	2
19	XHD001	GUARD, RAC tip	1		1	1	1	1	1
20	XHDxxx	SWITCH, RAC tip; 519 size included			1	1	1	1	
	XHDxxx	SWITCH, RAC tip; 519 size							1
20a✓	---	SEAL, fluid			1	1	1	1	1
20b✓	---	GASKET			1	1	1	1	1
20c	---	TIP, spray, XHD RAC			1	1	1	1	1
21*	179733	SEAL, sleeve	1	1	1	1	1	1	1
24	119740	O-RING			1	1			
26	287032	FILTER, 60 mesh included with gun	1	1	1	1	1	1	
	287034	FILTER, 60 mesh and 100 mesh combo	1	1	1	1	1	1	
29▲	222385	TAG, warning (not shown)	1	1	1	1	1	1	1
30	166969	GASKET		1					
31	220251	GUARD, flat tip		1					
32	163519	TIP, flat		1					
36*	194744	TOOL, repair, packing	1	1	1	1	1	1	1

--- Not for sale.

▲ Replacement Danger and Warning labels, tags, and cards are available at no cost.

* Parts included in Repair Kit 248837, purchased separately.

† Trigger kit (16) includes mounting hardware for either XTR5 or XTR7 gun.

‡ Handle is not pressure rated for use with the XTR 7. For an XTR 7, order handle 248952 and sleeve 276997 or 15E083 depending on your model.

✓ Included in OneSeal™ Repair Kit XHD010 (5 each per package, purchase separately).

★ Do not remove swivel. If the swivel needs to be replaced, order replacement handle kit 248952.

XTR7

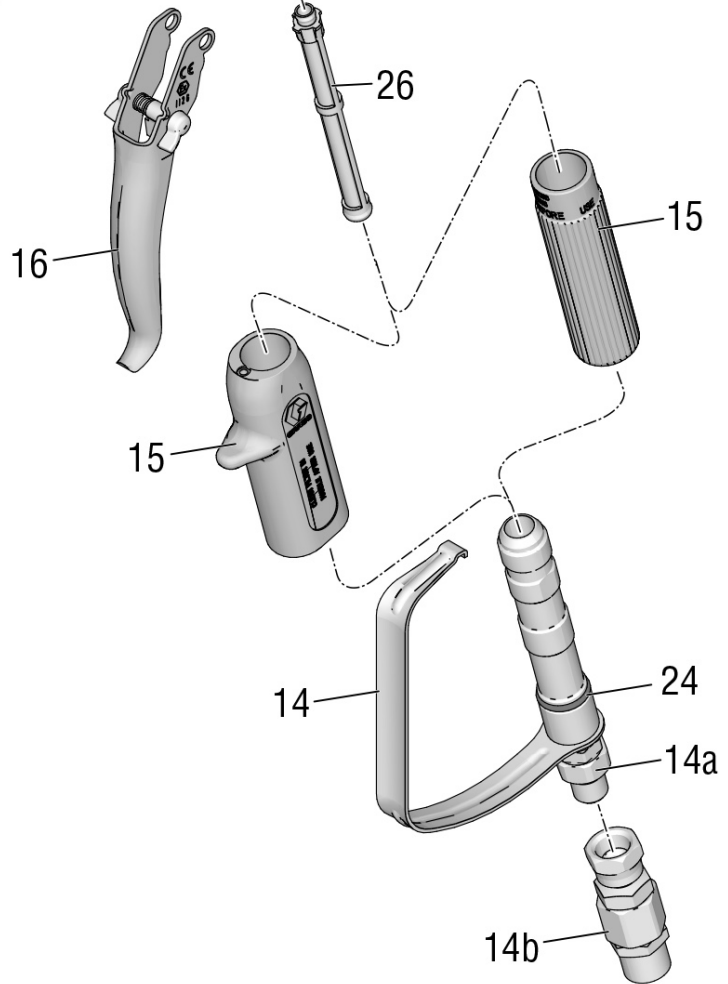
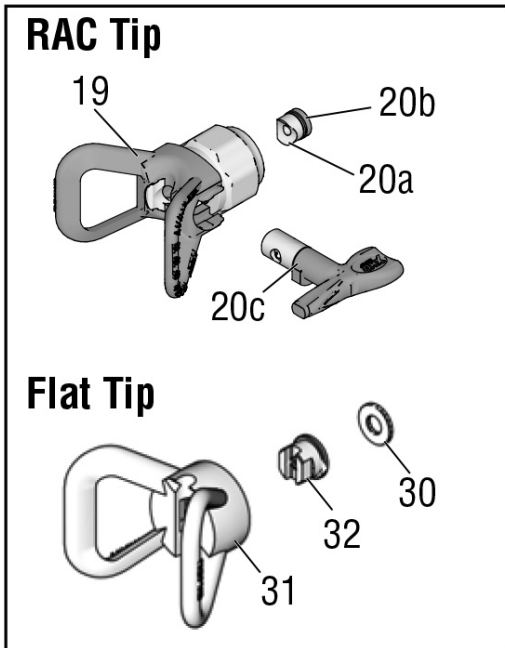
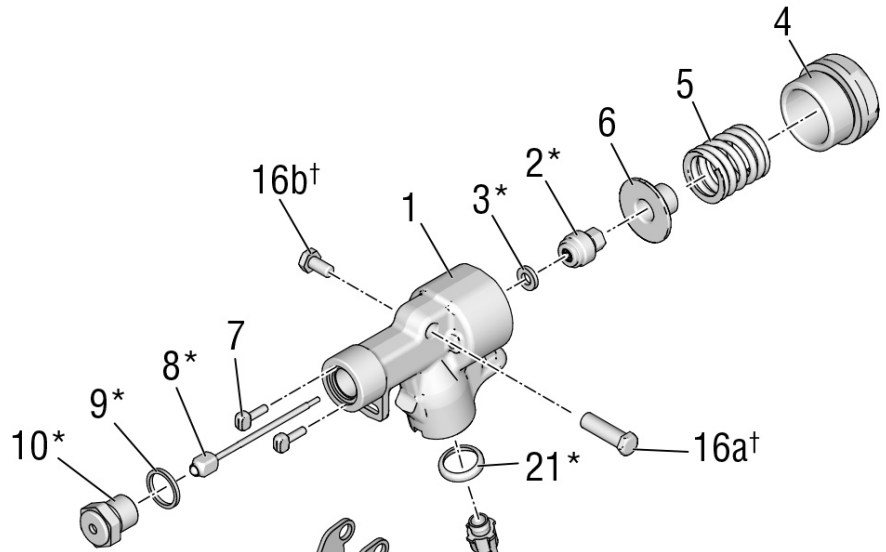

ti21835c

Parts

Ref.	Part	Description	Quantity							
			XTR700	XTR701	XTR702	XTR703	XTR704	XTR705	XTR706	17V677
1	15E178	BODY, gun	1	1	1	1	1	1		
	17V381	BODY, gun							1	1
2*	245881	SEAL, retainer assembly	1	1	1	1	1	1	1	1
3*	---	GASKET	1	1	1	1	1	1	1	1
4	15A864	CAP, end	1	1	1	1	1	1	1	1
5	117350	SPRING	1	1	1	1	1	1	1	1
6	15E088	RETAINER, needle	1	1	1	1	1	1	1	1
7	15E085	PIN, actuator	2	2	2	2	2	2	2	2
8*	248591	NEEDLE	1	1	1	1	1	1	1	1
9*	156766	GASKET	1	1	1	1	1	1	1	1
10*	245858	SEAT, valve	1	1	1	1	1	1	1	1
14	248952	KIT, repair, handle	1	1	1	1	1	1		
	17V749	KIT, repair, handle							1	1
14a★	---	SWIVEL								
14b	17G980	SWIVEL							1	1
15	276997	HANDLE SLEEVE, insulated			1	1			1	1
	15E083	HANDLE SLEEVE, round	1	1			1	1		
16	287449	TRIGGER KIT, 4-finger, straight; includes 16a and 16b	1	1			1			
	287451	TRIGGER KIT, 4-finger, curved; includes 16a and 16b			1				1	1
	287450	TRIGGER KIT, 2-finger; includes 16a and 16b				1		1		
16a†	192272	PIN, pivot	1	1	1	1	1	1	1	1
16b†	203953	SCREW, cap, #10-24	1	1	1	1	1	1	1	1
19	XHD001	GUARD, RAC tip	1		1	1	1	1	1	1
20	XHDxxx	SWITCH, RAC tip; 519 size included			1	1	1	1		
		SWITCH, RAC tip; 523 size included								1
		SWITCH, RAC tip; 531 size included							1	1
20a✓	---	SEAL, fluid			1	1	1	1	1	1
20b✓	---	GASKET			1	1	1	1	1	1
20c	---	TIP, spray, XHD RAC			1	1	1	1	1	1
21*	179733	SEAL, sleeve	1	1	1	1	1	1	1	1
24**	119740	O-RING	1	1	1	1	1	1	1	1
26	287032	FILTER, 60 mesh included with gun	1	1	1	1	1	1		
	287034	FILTER, 60 mesh and 100 mesh combo	1	1	1	1	1	1		

Parts

Ref.	Part	Description	Quantity							
			XTR700	XTR701	XTR702	XTR703	XTR704	XTR705	XTR706	17V677
29▲	222385	TAG, warning (not shown)	1	1	1	1	1	1	1	1
30	166969	GASKET		1						
31	220251	GUARD, flat tip		1						
32	163519	TIP, flat		1						
36*	194744	TOOL, repair, packing	1	1	1	1	1	1	1	1

--- Not for sale.

▲ Replacement Danger and Warning labels, tags, and cards are available at no cost.

* Parts included in Repair Kit 248837, purchased separately.

★ Do not remove swivel. If the swivel needs to be replaced, order replacement handle kit 248952.

† Trigger Kit (16) includes mounting hardware for either the XTR5 or XTR7 gun.

✓ Included in OneSeal™ Repair Kit XHD010 (5 each per package, purchase separately).

** Included in Handle Repair Kits 248952 and 17V749.

Technical Specifications

XTR5 and XTR7 Airless Spray Gun		
	US	Metric
Maximum working pressure (XTR5)	5000 psi	35 MPa, 345 bar
Maximum working pressure (XTR7)	7250 psi	50 MPa, 500 bar
Maximum fluid operating temperature	160°F	71°C
Noise (dBa)		
Maximum sound pressure	84.3 dBa at 6000 psi (41 MPa, 414 bar)	
Sound power	95.7 dBa at 6000 psi (41 MPa, 414 bar)	
<i>Sound pressure measured using the HD519 tip and water.</i>		
<i>Sound power tested per ISO-9614-2.</i>		
Inlet/Outlet Sizes		
Fluid inlet size	1/4 npsm (m) or 3/8 NPT (XTR706)	
Fluid orifice size	0.090 in.	2.3 mm
Materials of Construction		
Wetted materials on all models	Aluminum, stainless steel, acetal, polyethylene, nylon, polypropylene, carbide, polyurethane, solvent-resistant o-rings	
Notes		
All trademarks or registered trademarks are the property of their respective owners.		

Graco Standard Warranty

Graco warrants all equipment referenced in this document which is manufactured by Graco and bearing its name to be free from defects in material and workmanship on the date of sale to the original purchaser for use. With the exception of any special, extended, or limited warranty published by Graco, Graco will, for a period of twelve months from the date of sale, repair or replace any part of the equipment determined by Graco to be defective. This warranty applies only when the equipment is installed, operated and maintained in accordance with Graco's written recommendations.

This warranty does not cover, and Graco shall not be liable for general wear and tear, or any malfunction, damage or wear caused by faulty installation, misapplication, abrasion, corrosion, inadequate or improper maintenance, negligence, accident, tampering, or substitution of non-Graco component parts. Nor shall Graco be liable for malfunction, damage or wear caused by the incompatibility of Graco equipment with structures, accessories, equipment or materials not supplied by Graco, or the improper design, manufacture, installation, operation or maintenance of structures, accessories, equipment or materials not supplied by Graco.

This warranty is conditioned upon the prepaid return of the equipment claimed to be defective to an authorized Graco distributor for verification of the claimed defect. If the claimed defect is verified, Graco will repair or replace free of charge any defective parts. The equipment will be returned to the original purchaser transportation prepaid. If inspection of the equipment does not disclose any defect in material or workmanship, repairs will be made at a reasonable charge, which charges may include the costs of parts, labor, and transportation.

THIS WARRANTY IS EXCLUSIVE, AND IS IN LIEU OF ANY OTHER WARRANTIES, EXPRESS OR IMPLIED, INCLUDING BUT NOT LIMITED TO WARRANTY OF MERCHANTABILITY OR WARRANTY OF FITNESS FOR A PARTICULAR PURPOSE.

Graco's sole obligation and buyer's sole remedy for any breach of warranty shall be as set forth above. The buyer agrees that no other remedy (including, but not limited to, incidental or consequential damages for lost profits, lost sales, injury to person or property, or any other incidental or consequential loss) shall be available. Any action for breach of warranty must be brought within two (2) years of the date of sale.

GRACO MAKES NO WARRANTY, AND DISCLAIMS ALL IMPLIED WARRANTIES OF MERCHANTABILITY AND FITNESS FOR A PARTICULAR PURPOSE, IN CONNECTION WITH ACCESSORIES, EQUIPMENT, MATERIALS OR COMPONENTS SOLD BUT NOT MANUFACTURED BY GRACO. These items sold, but not manufactured by Graco (such as electric motors, switches, hose, etc.), are subject to the warranty, if any, of their manufacturer. Graco will provide purchaser with reasonable assistance in making any claim for breach of these warranties.

In no event will Graco be liable for indirect, incidental, special or consequential damages resulting from Graco supplying equipment hereunder, or the furnishing, performance, or use of any products or other goods sold hereto, whether due to a breach of contract, breach of warranty, the negligence of Graco, or otherwise.

FOR GRACO CANADA CUSTOMERS

The Parties acknowledge that they have required that the present document, as well as all documents, notices and legal proceedings entered into, given or instituted pursuant hereto or relating directly or indirectly hereto, be drawn up in English. Les parties reconnaissent avoir convenu que la rédaction du présente document sera en Anglais, ainsi que tous documents, avis et procédures judiciaires exécutés, donnés ou intentés, à la suite de ou en rapport, directement ou indirectement, avec les procédures concernées.

Graco Information

For the latest information about Graco products, visit www.graco.com.

For patent information, see www.graco.com/patents.

TO PLACE AN ORDER, contact your Graco distributor or call to identify the nearest distributor.

Phone: 612-623-6921 or Toll Free: 1-800-328-0211 Fax: 612-378-3505

All written and visual data contained in this document reflects the latest product information available at the time of publication. Graco reserves the right to make changes at any time without notice.

Original instructions. This manual contains English. MM 312145

Graco Headquarters: Minneapolis

International Offices: Belgium, China, Japan, Korea

GRACO INC. AND SUBSIDIARIES • P.O. BOX 1441 • MINNEAPOLIS MN 55440-1441 • USA
Copyright 2018, Graco Inc. All Graco manufacturing locations are registered to ISO 9001.

www.graco.com
Revision K, September 2018